



BICENTENNIAL CLASS OF 2015
A
 ORIENTATION

2011 STUDENT SCHEDULE OF EVENTS
 ALLEGHENY COLLEGE

WELCOME TO ALLEGHENY

We are excited that you are finally here! This schedule is your guide to Allegheny's New Student Orientation 2011. We hope that you find the various Orientation events helpful, informative and fun. You'll notice that we have a busy week planned for you, filled with a variety of activities. We strive to include events that will introduce you to many facets of Allegheny life: academics, social life, co-curricular activities, and much more.

Please keep this schedule with you throughout the Orientation week. The program includes a quick "Schedule at a Glance" followed by a detailed listing of the events with complete descriptions. You will also notice some words of wisdom from current and former students. Remember, they've all been where you are right now, so they speak from experience. We hope you will find this advice helpful!

If you have any questions, or need assistance at any time, please don't hesitate to ask one of the Peer Leaders or call the Learning Commons office at 814-332-2898. We want to help with your transition to Allegheny in any way possible.

The Mission of New Student Orientation

Our Orientation program is designed to help you:

DISCOVER Allegheny as a student on the campus and learn about all it has to offer.

CONNECT with fellow first year students, your Resident Advisor and Peer Leaders, as well as faculty and staff.

ENGAGE in the many activities offered by various offices, clubs and organizations on campus.

We encourage you to take part in as many activities as are offered during the next five days. These are your opportunities to meet your hallmates, classmates, and new friends!

For up-to-the-minute information get Orientation updates via text message by texting **follow alleghenyorient** to 40404.



Orientation Checklist

FINISH SETTING UP YOUR ROOM

Get your room organized with your roommate during this time. Don't forget that the CATA makes trips to WalMart if you need to go!

TAKE CARE OF PAPERWORK

Missed the Human Resources meeting for jobs? Find the office of Human Resources on the second floor of Bently Hall.

FIND YOUR WAY AROUND CAMPUS

Figure out where your classes are before you head out Thursday morning. Walk to their respective buildings and classrooms and time your route. This way you'll be prepared for your first day.

PICK UP YOUR BOOKS

The bookstore opens at 8:00 a.m. on Wednesday or go to the Post Office if you ordered them online!

MAKE A SCHEDULE

Organize your time by making a schedule for each day. Make sure you include classes, work, and times for homework and free time.

RELAX

After a busy week, make sure you take time to relax. Go to the Wise Center to get a workout in, walk around your new home, and get plenty of sleep because tomorrow is a big day!

Student Schedule at a Glance

SATURDAY, AUGUST 27

10:00 a.m. – 2:00 p.m.

Residence Hall Move-In & Orientation Check-In

10:00 a.m. – 3:00 p.m.

Campus & Local Services

Noon & 2:00 p.m.

Mandatory Student Employment Meetings

1:00 p.m. – 4:00 p.m.

Alumni Affairs Tent

4:00 p.m.

Multicultural Student and Family Reception

4:30 p.m.

Catholic Mass & Reception

6:00 p.m. – 7:00 p.m.

Family Welcome Dessert Open House

7:00 p.m.

Brian C. Johnson - Reel Diversity

8:00 p.m.

Continued Conversations with Peer Leaders

10:00 p.m.

Residence Hall Programs

SUNDAY, AUGUST 28

8:30 a.m.

Breakfast Receptions

9:00 a.m. – 11:00 a.m.

Campus Services Available

10:00 a.m.

Ecumenical Service & Hillel Bagel Brunch

Noon

Matriculation Ceremony

2:30 p.m.

FS Class Meeting

3:45 p.m.

Meet with your RA

4:00 p.m.

Brett Sokolow, "Drunk Sex or Date Rape: Can You Tell the Difference?"

5:00 p.m. – 6:45 p.m.

Continued Conversations with your RA

7:00 p.m.

Residence Hall Community Meetings

MONDAY, AUGUST 29

9:00 a.m.

FS Class Meetings

10:00 a.m.

Individual Advising Meetings

10:00 a.m. – Noon

Math, Chemistry, Language, & Music Consultations

10:00 a.m. – 4:00 p.m.

Academic Breakout Sessions

Noon

Lunch with your RA

5:00 p.m.

Spirit of Allegheny Dinner

8:00 p.m.

Survival Bingo

TUESDAY, AUGUST 30

ALL DAY

Network Training

10:00 a.m. – Noon

Schedule Adjustment Time

10:00 a.m. – 2:00 p.m.

Social / Wellness Breakout Sessions

Noon

I ♥ Meadville Picnic

3:00 p.m.

Pre-Health & Pre-Law Reception

6:00 p.m.

Class Photo

7:00 p.m.

All College Celebration

9:00 p.m.

GAP presents hypnotist Dale K.

WEDNESDAY, AUGUST 31

ALL DAY

Network Training

10:30 a.m. – 11:30 a.m.

Union Latina Brunch

Noon – 1:00 p.m.

Therapy Dogs

4:00 p.m. – 6:00 p.m.

IFC Picnic

4:30 p.m. – 6:00 p.m.

Faith Fair

8:00 p.m.

Sue Plunkett's Sex Talk

DINING HOURS

SATURDAY, AUGUST 27

McKINLEY'S FOOD COURT

10:00 a.m. – 2:00 p.m.

4:00 – 6:45 p.m.

BROOKS DINING HALL

4:00 – 6:45 p.m.

SUNDAY, AUGUST 28

McKINLEY'S FOOD COURT

1:00 – 2:30 p.m.

5:00 – 6:45 p.m.

BROOKS DINING HALL

1:00 – 2:30 p.m.

5:00 – 6:45 p.m.

MONDAY, AUGUST 29

McKINLEY'S FOOD COURT

8:15 – 9:45 a.m.

Noon – 2:00 p.m.

5:00 – 6:45 p.m.

BROOKS DINING HALL

8:15 – 9:45 a.m.

Noon – 2:00 p.m.

5:00 – 6:45 p.m.

TUESDAY, AUGUST 30

McKINLEY'S FOOD COURT

8:15 – 9:45 a.m.

BROOKS DINING HALL

8:15 – 9:45 a.m.

Noon – 2:00 p.m.

* All new students will have an Orientation meal plan on their AllCard to use in Brooks and McKinley's



Notes

Office/Services Hours

Saturday, August 27

Computing Services (Murray Hall & Baldwin)	12:00 p.m. – 5:00 p.m.
Computing Services (Campus Center, 206)	10:00 a.m. – 3:00 p.m.
Bookstore (Campus Center)	10:00 a.m. – 4:00 p.m.
Orientation Information Table (Campus Center)	10:00 a.m. – 2:00 p.m.
Post Office (Campus Center)	10:00 a.m. – 4:00 p.m.
Winslow Health Center (Schultz Hall, Park Ave. Entrance)	11:00 a.m. – 3:00 p.m.

Sunday, August 28

Computing Services (Murray Hall & Baldwin)	12:00 p.m. – 4:00 p.m.
Orientation Information Table (Campus Center)	8:30 a.m. – 12:00 p.m.
Bookstore (Campus Center)	10:00 a.m. – 4:00 p.m.
Dean of Students, Counseling Center, Res. Life, Disability Services (CC)	9:00 a.m. – 11:00 a.m.
Winslow Health Center (Schultz Hall, Park Ave. Entrance)	9:00 a.m. – 12:00 p.m.

Saturday, August 27

10:00 a.m. – 2:00 p.m.

RESIDENCE HALL MOVE-IN/ ORIENTATION CHECK-IN

Pick up your room keys and check in for New Student Orientation at your assigned residence hall. Student volunteers will help you unload your car and move your stuff into your room. Then head to the Campus Center to pick up your AllCard. Check-in for commuter students is in the Campus Center lobby.

10:00 a.m. – 3:00 p.m.

CAMPUS AND LOCAL SERVICES (CAMPUS CENTER LOBBY)

The following offices and services will be available in the Campus Center: AllCard (student ID cards), Financial Services (billing, Shop account deposits), Orientation Information, Armstrong Campus TV, Crawford Area Transportation Authority (CATA), Local Banks.

Noon or 2:00 p.m.

MANDATORY STUDENT EMPLOYMENT MEETINGS (SHAHER AUDITORIUM)

This meeting is mandatory for all students seeking a job on campus. Human Resources will review how to find a job, complete required paperwork, and the process for receiving payments. Please bring two forms of ID; one photo ID (passport or driver's license) along with a social security card, birth certificate, etc.

1:00 p.m. – 4:00 p.m.

ALUMNI WELCOME TENT (GATOR QUAD)

This will be a tent staffed by alumni with refreshments and friendly conversation for new students and their families. The tent will be located on Gator Quad (Campus Center lawn). This offers a great chance to welcome students to our community and answer general Allegheny questions.

4:00 p.m.

MULTICULTURAL STUDENT AND FAMILY RECEPTION (TIPPIE ALUMNI CENTER)

This reception is for anyone who is interested in diversity or multiculturalism at Allegheny College. Food and beverages will be served.

4:30 p.m.

CATHOLIC MASS (FORD CHAPEL)

The Newman Association invites incoming Catholic students and their families to get acquainted with Allegheny's Catholic campus ministry and enjoy refreshments following the first Mass of the year, which will be said by Father Marc Solomon.

DINNER ON YOUR OWN

Enjoy dinner in McKinley's, or feel free to venture off campus to have dinner in Meadville.

6:00 p.m.

FAMILY WELCOME DESSERT AND OPEN HOUSE (GATOR QUAD, RAIN LOCATION: CAMPUS CENTER LOBBY)

The campus community welcomes you to the Allegheny family! Enjoy Gator-inspired desserts and meet with students and staff members from all over campus.

7:00 p.m.

BRIAN C. JOHNSON - REEL DIVERSITY (SHAHER AUDITORIUM)

Brian's creative keynote, Reel Diversity, frames the diversity conversation through modern film. By sharing clips of well-known films and discussing the messages they consciously or unconsciously give, Brian allows every student to see himself or herself as diverse. Students laugh and remember some of their favorite movies, and from there, an interactive keynote about interculturalism can begin.

8:00 p.m.

STUDENT FOLLOW UP CONVERSATIONS WITH PEER LEADERS (CC LOBBY)

Meet your peer leaders in the Campus Center Lobby after Brian C. Johnson's program, Reel Diversity. Students will have an opportunity to further discuss diversity topics with their Peer Leaders and with Allegheny community members throughout the academic year.

10:00 p.m.

RESIDENCE HALL ACTIVITIES (VARIOUS HALLS)

Get to know your roommate and connect with your hallmates as your RAs host different programs in each hall.

Sunday, August 28

8:30 a.m.

CONTINENTAL BREAKFAST RECEPTIONS

Students and families should feel free to attend any reception you feel comfortable with to meet classmates you share something in common with. You are welcome and encouraged to attend more than one reception. Brooks and McKinley's will also be open for breakfast this morning.

ALLEGHENY LEGACIES (TIPPIE ALUMNI CENTER) – For members of the Class of 2015 who have family members who graduated from Allegheny.

TRANSFER STUDENTS (GROUNDS FOR CHANGE, CAMPUS CENTER)

GATOR OUT-OF-STATERS (CAMPUS CENTER, ROOM 301) – New students coming from outside of Pennsylvania or farther than three hours from Meadville in PA can take this opportunity to connect.

VARSITY ATHLETES (WISE CENTER, CONCOURSE LEVEL) – Recruited varsity athletes and their families can meet each other, their coaches and the Director of Athletics during this reception.

NEW CONNECTIONS (ART GALLERY) – Any first generation new student and family can attend this reception and be welcomed by the Allegheny student president and vice president as you begin a new legacy at Allegheny.

9:00 a.m. – 11:00 a.m.

DEAN OF STUDENTS, COUNSELING CENTER, RESIDENCE LIFE AND DISABILITY SERVICES TABLES (CAMPUS CENTER, 301, 302, 303, 317, 318,)

Representatives from each department will be available during this time for consultations and general information.

10:00 a.m.

ECUMENICAL SERVICE OF MORNING PRAYER (FORD MEMORIAL CHAPEL)

Join us for fellowship and a light breakfast, followed by a prayer service for this time of transition, led by Chaplain Jane Ellen Nickell.

HILLEL BAGEL BRUNCH (JEWISH COMMUNITY CENTER, 380 PARK AVENUE, BEHIND STEFFEE)

Incoming students and their families are invited to a reception to meet members of the Allegheny and Meadville Jewish communities and learn about opportunities for getting involved in Jewish life on campus.

Noon – 1:00 p.m.

MATRICULATION (CAMPUS CENTER, SHAHER AUDITORIUM)

This ceremony welcomes students as members of the Allegheny community and includes taking the formal pledge to the Honor Code. Immediately following the formal ceremony, students and families will have the opportunity to engage in discussion with our Dean of Students. Dress for Matriculation is casual.

LUNCH ON YOUR OWN

Students and families are welcome to have lunch in Brooks or McKinley's or go off campus and explore Meadville. Just make sure you are on time for your FS meeting!

Get to know your professors. They can help you out in so many ways— internships, jobs, career choices...

Heidi

Take advantage of all the clubs and programs at Allegheny. Give a few different organizations a try.

Zeben

If you have a problem with your roommate, talk to them. Don't just write about it in your Facebook status!

Lynn

Don't underestimate the power of simply saying "hello" to an unfamiliar face.

Jackie

Be involved on campus. Don't just spend your days Skyping with your high school friends.

Abby

Notes



2:30 p.m.

FS CLASS MEETING (VARIOUS LOCATIONS: CHECK THE LABEL ON YOUR ORIENTATION FOLDER)

Meet your FS class and set the course for the next few days. Your Orientation folder label will list your advisor's name and meeting location.

3:45 p.m.

MEET WITH YOUR RA (VARIOUS RESIDENCE HALLS)

Meet your RA and hallmates to walk together to the following program.

4:00 p.m.

"DRUNK SEX OR DATE RAPE: CAN YOU TELL THE DIFFERENCE?" (CAMPUS CENTER, SHAFER AUDITORIUM)

Allegheny is proud to present Brett Sokolow, a five-time Allegheny Orientation speaker. Date rape is an issue that every college student needs to be informed about, both men and women. Along with your classmates, learn the difference between drunk sex and date rape during this interactive program. After hearing the facts of a real case, the audience must determine if the case presented was drunk sex or date rape.

5:00 p.m.

CONTINUED CONVERSATIONS WITH YOUR RA (VARIOUS RESIDENCE HALLS)

Your RA will inform you where to meet to discuss with your fellow residents your thoughts and impressions of Brett Sokolow's program.

7:00 p.m.

COMMUNITY MEETINGS (VARIOUS RESIDENCE HALLS)

Your RA will let you know where to meet as you have your first official community meeting of the year. Meet the rest of your community members, and develop community standards.

Monday, August 29

9:00 a.m.

FS CLASS MEETING (VARIOUS LOCATIONS)

Meet with FS class to discuss class schedules and set up times to meet with your advisor for an individual meeting.

10:00 a.m.

INDIVIDUAL ADVISING MEETINGS (WITH FS ADVISOR)

Your advisor will let you know where and when to meet to discuss your schedule and plans for Allegheny.

10:00 a.m. – Noon

ACADEMIC BREAKOUT SESSIONS

Check your Orientation folder for your assignment and location.

LIBRARY TOURS (PELLETIER LIBRARY)

Take an interactive tour of the library and learn about the many resources it has to offer.

HOW TO TALK TO PROFESSORS

Sit in with a professor and learn how to appropriately approach professors in an academic manner, ease the anxiety of going to office hours, and how to get the most out of your relationship with professors.

MAKING THE ACADEMIC TRANSITION

Learn about the differences between college and high school academics, what to expect, and how to use the resources available at Allegheny to make a smooth transition.

10:00 a.m. – Noon

MATH, CHEMISTRY, LANGUAGE, AND MUSIC CONSULTATIONS

If you have questions about your placement exams or simply have questions about a department, stop by the following offices.

Department	Location	Professor
Math	Arter 104E Arter 116	Clay Eilers
Chemistry Language Music	Doane Ruter, first floor Arnold Hall of Music	Deckert Modern & Classical Language Professors Chein

Noon

LUNCH WITH YOUR RA

Your RA will tell you where to meet for lunch.

2:00 p.m. – 4:00 p.m.

ACADEMIC BREAKOUT SESSIONS

Check your Orientation folder for your assignment and location.

LIBRARY TOURS (PELLETIER LIBRARY)

Take an interactive tour of the library and learn about the many resources it has to offer.

HOW TO TALK TO PROFESSORS

Sit in with a professor and learn how to appropriately approach professors in an academic manner, ease the anxiety of going to office hours, and how to get the most out of your relationship with professors.

MAKING THE ACADEMIC TRANSITION

Learn about the differences between college and high school academics, what to expect, and how to use the resources available at Allegheny to make a smooth transition.

5:00 p.m.

SPIRIT OF ALLEGHENY DINNER (BROOKS LAWN, RAIN LOCATION: BROOKS DINING HALL)

Get tons of Gator giveaways and prizes from Chompers, our mascot, during this spirit-filled dinner. Don't forget to wear your blue and gold!

8:00 p.m.

SURVIVAL BINGO (CAMPUS CENTER LOBBY)

Join us for our most popular late night program sponsored by Allegheny's student-run organization GAP (Gator Activities Programming). Win prizes you will need to survive college!

Don't be afraid to approach a professor for help. Every professor is willing to sit down with you and explain a concept or help you through a hard problem.

Michelle

Make a schedule and stick to it! It will help you manage your activities and make the most of your time.

Justin

Do not schedule more than two science or math classes in a semester.

Rachel

Take advantage of every opportunity that is given to you at Allegheny. Don't hold back. Step up to the challenge.

Jennifer

Notes

Tuesday, August 30

10:00 am. – Noon

SCHEDULE ADJUSTMENT PERIOD (FACULTY OFFICES)

This is primarily for new students who received fewer than 16 credit hours. Peer Leaders will be available for help.

All Day

NETWORK TRAINING (CHECK ORIENTATION FOLDER FOR LOCATION)

Join your peer leaders and FS class to learn the ins and outs of Allegheny's computer systems. Learn how to use Sakai (very popular with faculty for posting articles, having online class discussions and turning in papers), the public computers on campus, your Google mail and calendar and more.

10:00 a.m. & 11:00 a.m.

SOCIAL AND WELLNESS BREAKOUT SESSIONS

Feel free to join any of the following sessions below.

COMMUNITY SERVICE (SCHULTZ EAST ALCOVE)

Come join the office of ACCEL to learn about local community service projects and opportunities available in the Meadville area.

DOWNTOWN TOURS OF MEADVILLE (TIPPIE ALUMNI CENTER, CATA)

Meet Davies Leaders in front of the Tippie Alumni Center at 10:00 a.m. for a downtown tour of Meadville on the local CATA Bus.

RUNNING CLUB (OUTSIDE WISE CENTER)

For beginning to advanced runners, learn a simple running route around the campus and town. There will be a short and long run leaving at the same time, rain or shine.

GREEN TOURS (GATOR QUAD)

Allegheny is on the cutting edge of national campus sustainability. Join the Green Tour to explore our green buildings, rain gardens, composting program, and learn how you, too, can be a Green Gator!

WELLNESS SESSIONS

YOGA (Montgomery Dance Studio, 10 a.m. only) **PICK UP BASKETBALL** (Blue Courts, Wise Center)

POOL OPEN (Wise Center)

Noon

I ♥ MEADVILLE PICNIC (BROOKS WALK, RAIN LOCATION: BROOKS HALL)

Meet your classmates on the lawn to discover what Allegheny's hometown has to offer. This will be a great chance to pick up some menus, brochures, and coupons for local businesses and restaurants!

2:00 p.m. & 3:00 p.m.

SOCIAL AND WELLNESS BREAKOUT SESSIONS

Feel free to join any of the following sessions below.

COMMUNITY SERVICE (SCHULTZ EAST ALCOVE)

Come join the office of ACCEL to learn about local community service projects and opportunities available in the Meadville area.

DOWNTOWN TOURS OF MEADVILLE (TIPPIE ALUMNI CENTER, CATA)

Meet Davies Leaders in front of the Tippie Alumni Center at 2:00 p.m. for a downtown tour of Meadville on the local CATA Bus.

RUNNING CLUB (OUTSIDE WISE CENTER)

For beginning to advanced runners, learn a simple running route around the campus and town. There will be a short and long run leaving at the same time, rain or shine.

GREEN TOURS (GATOR QUAD)

Allegheny is on the cutting edge of national campus sustainability. Join the Green Tour to explore our green buildings, rain gardens, composting program, and learn how you, too, can be a Green Gator!

WELLNESS SESSIONS

YOGA (Montgomery Dance Studio, 2 p.m. only) **PICK UP BASKETBALL** (Blue Courts, Wise Center)

POOL OPEN (Wise Center)

SPINNING CLASS (Wise Center, 3 p.m. only)

Make friends with similar interests by going to every single club meeting that interests you. Then pick one or two that fit you best and have people in them that you relate to. Getting involved in the Allegheny community early on is important to getting the most out of your college experience.

Emilie

Sleep is a very good thing.

Ryan

3:00 p.m.

PRE-HEALTH & PRE-LAW RECEPTION (REIS HALL ROTUNDA, CC 301, 302)

Potential pre-health and pre-law students can come connect with other students interested in health and law careers. Current students will be there to share advice, answer questions, and offer refreshments.

6:00 p.m.

CLASS PHOTO

Be a part of history! This photo will be showcased at your future class reunions forever!

7:00 p.m.

ALL-COLLEGE CELEBRATION (CAMPUS CENTER)

Win prizes in our casino-themed lobby, get your picture on a keychain at "Picture This", win prizes, and pick up your orientation T-shirt on the 3rd floor of the Campus Center. Make sure you've signed up for orientation updates on your phone (text follow alleghenyorient to 40404) because instructions to win even more prizes will be given out via text.

9:00 p.m.

GAP PRESENTS HYPNOTIST DALE K (SHAHER AUDITORIUM)

Dale K quickly received attention from his peers and press when they noticed his ability to hypnotize at an abnormally young age. His obsession with bringing his hypnosis events to the masses is legendary. Dale K is a popular must see favorite with universal appeal!

Campus Activities on Wednesday

All Day Network Training (check orientation folder for location)

10:30 a.m. Union Latina Brunch (Tippie Hall)

Join the members of Union Latina for brunch as they welcome the Class of 2015 to campus. Everyone is welcome to come, eat good food and meet new friends.

Noon Therapy Dogs (Campus Center Lobby)

A special event with Therapy Dogs to welcome students back will be available in the Campus Center lobby.

4:00 p.m. Interfraternity Council Picnic (Brooks Lawn)

First-year men are invited to meet Allegheny's fraternity members and get some free food. We'll be grilling out on Gator Quad, come join us!

4:30 p.m. Faith Fair (Gator Quad)

Enjoy an evening of fellowship, food and fun games. This is your chance to meet students and staff from fellowship groups for Christian, Jewish, Muslim and Unitarian students, as well as our Interfaith Fellowship for all interested students. For info contact Spiritual and Religious Life Office at 814-332-2800 or jnickell@allegheny.edu.

8:00 p.m. Sue Plunkett's Sex Talk (Shafer Auditorium)

Allegheny's tradition is back by popular demand! Sue Plunkett, Director of the Winslow Health Center, helps you learn in a humorous way what you didn't learn in high school.

TBA Association of Caribbean Students Dance Workshop (Montgomery Studio)

Join the Association of Caribbean Students for a special dance workshop.

Important Orientation Phone Numbers

Allegheny area code: 814	
Safety and Security	332-3357
Orientation Questions (Learning Commons)	332-2898
Residence Life	332-3865
Dean of Students	332-4356
Counseling Center	332-4368
Health Center	332-4355
User Services (Computer Support)	332-2755
Financial Aid	332-2701
Financial Services	332-2360
Human Resources	332-2312

THU SEPT 1
First day of classes!



Please use this space for notes

Large empty rectangular box for notes.

Please use this space for notes

Large empty rectangular box for notes.

ALLEGHENY COLLEGE

ALLEGHENY COLLEGE

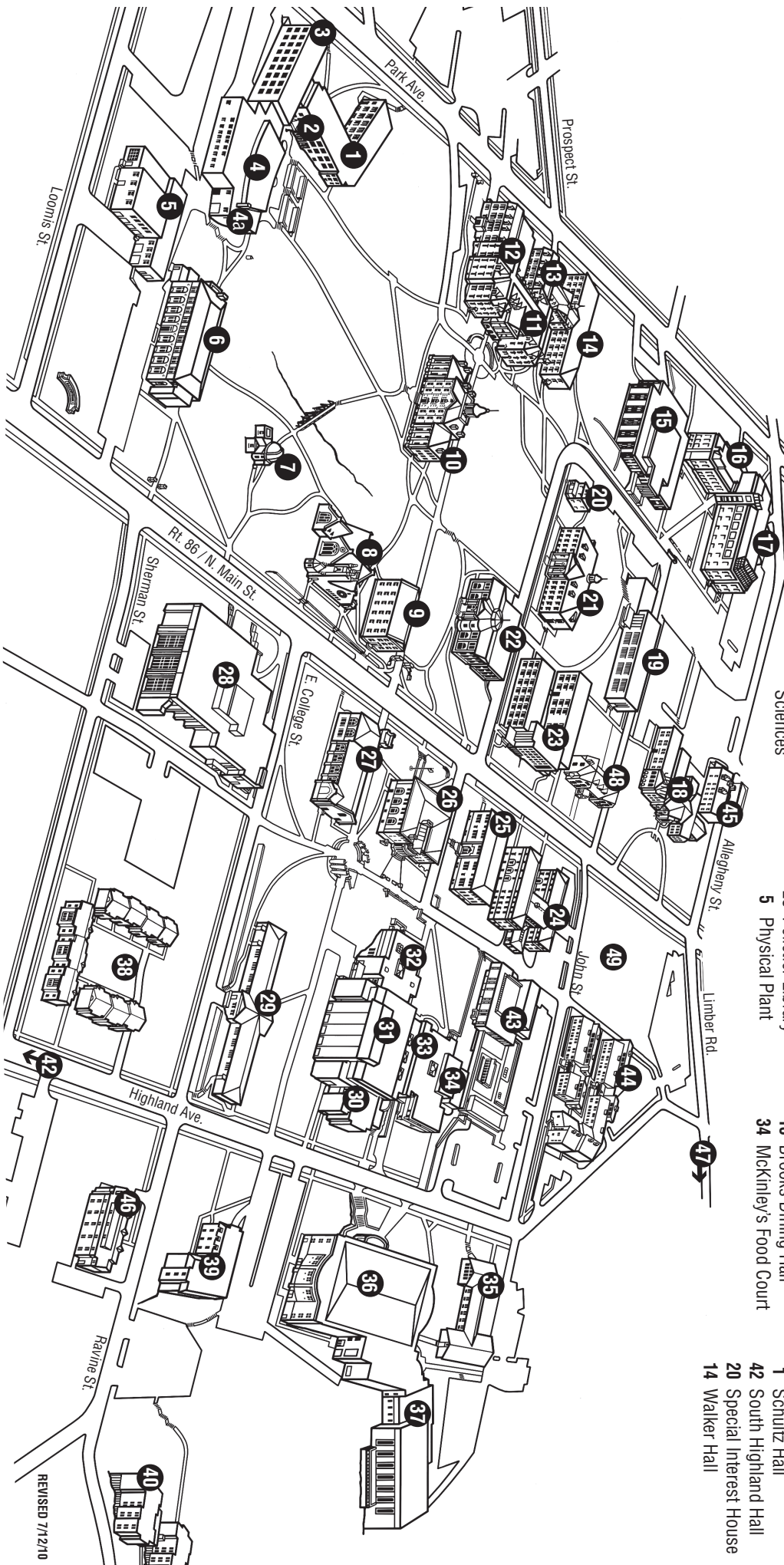
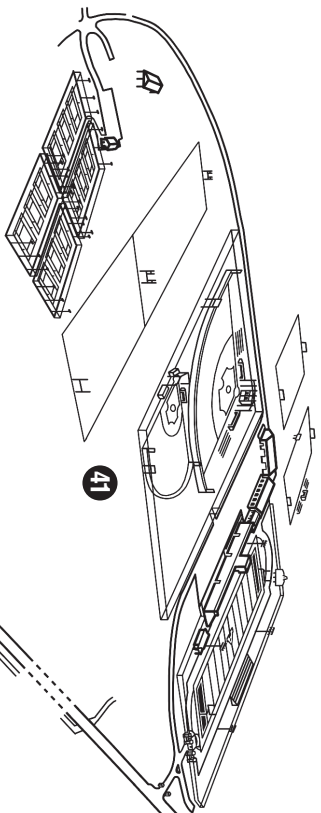

ACADEMICS

- 25 Alden Hall
- 30 Arnold Hall of Music
- 21 Arter Hall
- 6 Carnegie Hall
- 15 Carr Hall
- 32 Doane Hall (Art)
- 16 Doane Hall of Chemistry
- 27 Montgomery
- 29 Murray Hall
- 18 Oddfellows
- 19 Quigley Hall
- 9 Ruter Hall
- 17 Steffee Hall of Life Sciences

ADMINISTRATION/GENERAL

- 43 Vukovich Center for Communication Arts
- 48 454 House
- Admissions/Financial Aid
- 10 Bentley Hall
- 4a East Alcove Meeting Room
- 2 Financial Services
- 8 Ford Memorial Chapel
- 33 Henderson Campus Center
- 7 Newton Observatory
- 28 Palletier Library
- 5 Physical Plant

ATHLETICS

- 22 Reis Hall
- 4 Schultz Banquet Hall
- 31 Shafer Auditorium
- 26 Tripple Alumni Center at Cochran Hall
- 3 Winslow Health Center
- 37 Mellon Recreation Building
- 41 Robertson Athletic Complex
- 36 Wise Sport & Fitness Center

DINING

- 13 Brooks Dining Hall
- 34 McKinley's Food Court
- 47 Allegheny Commons
- 45 Allegheny Hall
- 23 Baldwin Hall
- 11 Brooks Hall
- 24 Cafisch Hall
- 38 College Court
- 35 Crawford Hall
- 39 Edwards Hall
- 12 Halings Hall
- 44 North Village
- 49 North Village II
- 46 Phi Kappa Psi Building
- 40 Ravine-Narvik Hall
- 1 Schultz Hall
- 42 South Highland Hall
- 20 Special Interest House
- 14 Walker Hall

ALLEGHENY COLLEGE

www.allegheny.edu/visitcampus

520 N. MAIN STREET • MEADVILLE, PA 16335

REVISED 7/12/10